

ASSEMBLY INSTRUCTIONS CHAIR

ASSEMBLY
REQUIREMENTS:

1-Person
Assembly

20 Minutes
Assembly Time
Per Chair
(Approximate)



Thank you for purchasing our product!

Please refer and use this assembly instruction to assemble the product. Contact our customer service department in case there are any missing or damage parts or hardware.

We appreciate your business!

ASSEMBLY PREPARATION

1. Remove all packaging materials, staples and packing straps from the carton.
2. Refer to Parts List and Hardware List and ensure they are complete before you start assembling.
3. Place all wooden parts on a clean, flat and soft surface (e.g. carpet or rug) to prevent parts from getting scratched.

SAFETY PRECAUTION:

1. KEEP ALL HARDWARE PARTS OUT OF REACH OF CHILDREN.
2. DISPOSE PLASTIC PACKAGING MATERIAL IMMEDIATELY TO AVOID ANY RISK OF SUFFOCATION TO CHILDREN AND ANIMALS.

TIPS FOR ASSEMBLY:







1. Allow ample room for assembly and in close proximity to where product will be placed.
2. Assemble the product on a surface that does not scratch or damage the exterior gloss and finish of the furniture.
3. Please check all of the parts and quantities are included before assembly. Contact customer service for missing parts.
4. Identify all of the parts, hardware and quantities required for each step.
5. During assembly, do not over-tighten any fittings as this may cause damage.
6. DO NOT USE POWER TOOLS TO ASSEMBLE THIS PRODUCT.
7. Always place the product on a flat surface.
8. Do not sit or stand on the partially assembled product; only use the product for which it is intended.

CARE AND MAINTENANCE

- Use a slightly damp cloth to clean the product. Do not use bleach or abrasive cleaning material.
- Check all the fittings periodically and re-tighten as necessary. Do not use the product if any of the parts is damaged or broken.
- Never allow any kind of liquid to remain on your furniture. Absorption can cause wood to warp or delaminate.
- Do not place hot items (e.g. hot drinks) directly onto the wood surface.
- Do not drag and/or pull the furniture.

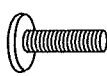
This product is for indoor and household use only - not for commercial use.

ASSEMBLY INSTRUCTIONS CHAIR

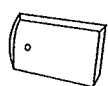
PARTS & HARDWARE LIST			
Ax1  Seat	Bx1  Leg	Cx4  Screw	Dx4  Flat Washer
Ex4  Spring Washer	Fx1  Allen Key	Gx4  Plastic Case	

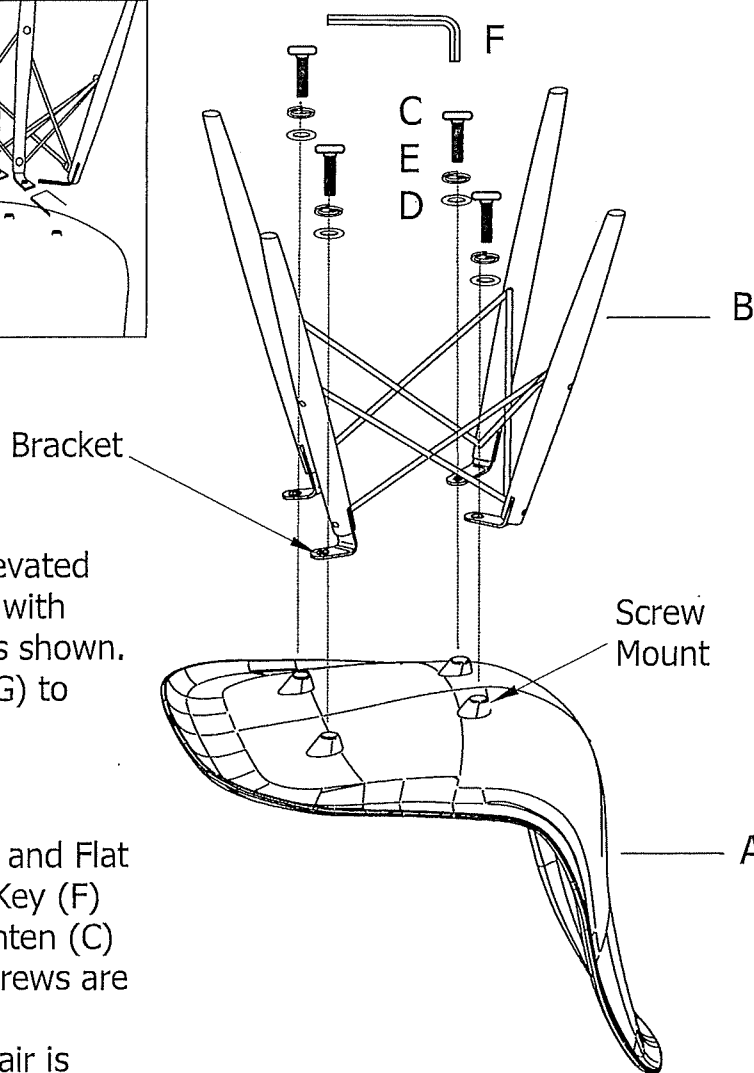
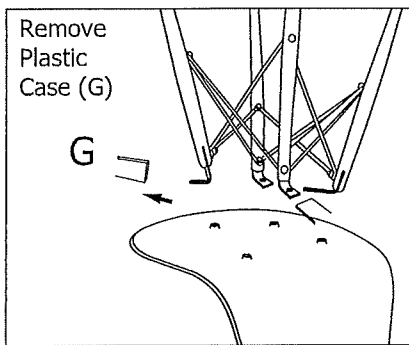

- a) Place Seat (A) on an elevated surface (e.g. table top) with bottom-side faced up as shown.
 - b) Remove Plastics Case (G) to expose bracket.
 - c) To fasten Leg to Seat, insert Screw (C) fitted with Spring Washer (E) and Flat Washer (D). Use Allen Key (F) to drive (C). Do not tighten (C) completely until all 4 screws are in place.
- The assembly of the chair is complete. Place the chair upright.

ASSEMBLY INSTRUCTIONS

DINING TABLE

ASSEMBLY
REQUIREMENTS:

2-Person
Assembly

20 Minutes
Assembly Time
(Approximate)

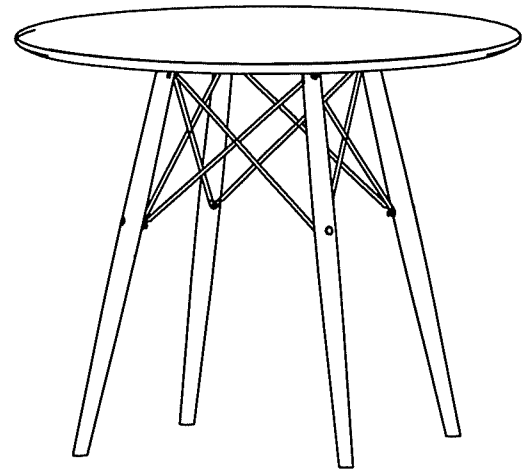

Thank you for purchasing our product!

Please refer and use this assembly instruction to assemble the product. Contact our customer service department in case there are any missing or damage parts or hardware.

We appreciate your business!

ASSEMBLY PREPARATION

1. Remove all packaging materials, staples and packing straps from the carton.
2. Refer to Parts List and Hardware List and ensure they are complete before you start assembling.
3. Place all wooden parts on a clean, flat and soft surface (e.g. carpet or rug) to prevent parts from getting scratched.

SAFETY PRECAUTION:

1. KEEP ALL HARDWARE PARTS OUT OF REACH OF CHILDREN.
2. DISPOSE PLASTIC PACKAGING MATERIAL IMMEDIATELY TO AVOID ANY RISK OF SUFFOCATION TO CHILDREN AND ANIMALS.

TIPS FOR ASSEMBLY:





1. Allow ample room for assembly and in close proximity to where product will be placed.
2. Assemble the product on a surface that does not scratch or damage the exterior gloss and finish of the furniture.
3. Please check all of the parts and quantities are included before assembly. Contact customer service for missing parts.
4. Identify all of the parts, hardware and quantities required for each step.
5. During assembly, do not over-tighten any fittings as this may cause damage.
6. DO NOT USE POWER TOOLS TO ASSEMBLE THIS PRODUCT.
7. Always place the product on a flat surface.
8. Do not sit or stand on the partially assembled product; only use the product for which it is intended.

CARE AND MAINTENANCE

- Use a slightly damp cloth to clean the product. Do not use bleach or abrasive cleaning material.
- Check all the fittings periodically and re-tighten as necessary. Do not use the product if any of the parts is damaged or broken.
- Never allow any kind of liquid to remain on your furniture. Absorption can cause wood to warp or delaminate.
- Do not place hot items (e.g. hot drinks) directly onto the wood surface.
- Do not drag and/or pull the furniture.

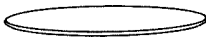
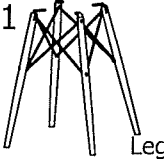
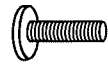
This product is for indoor and household use only - not for commercial use.

ASSEMBLY INSTRUCTIONS DINING TABLE

PARTS & HARDWARE LIST			
<p>Ax1</p>  <p>Table Top</p>	<p>Bx1</p>  <p>Leg</p>	<p>Cx4</p>  <p>Screw</p>	<p>Dx4</p>  <p>Flat Washer</p>
<p>Ex4</p>  <p>Spring Washer</p>	<p>Fx4</p>  <p>Mat</p>	<p>Gx1</p>  <p>Allen Key</p>	

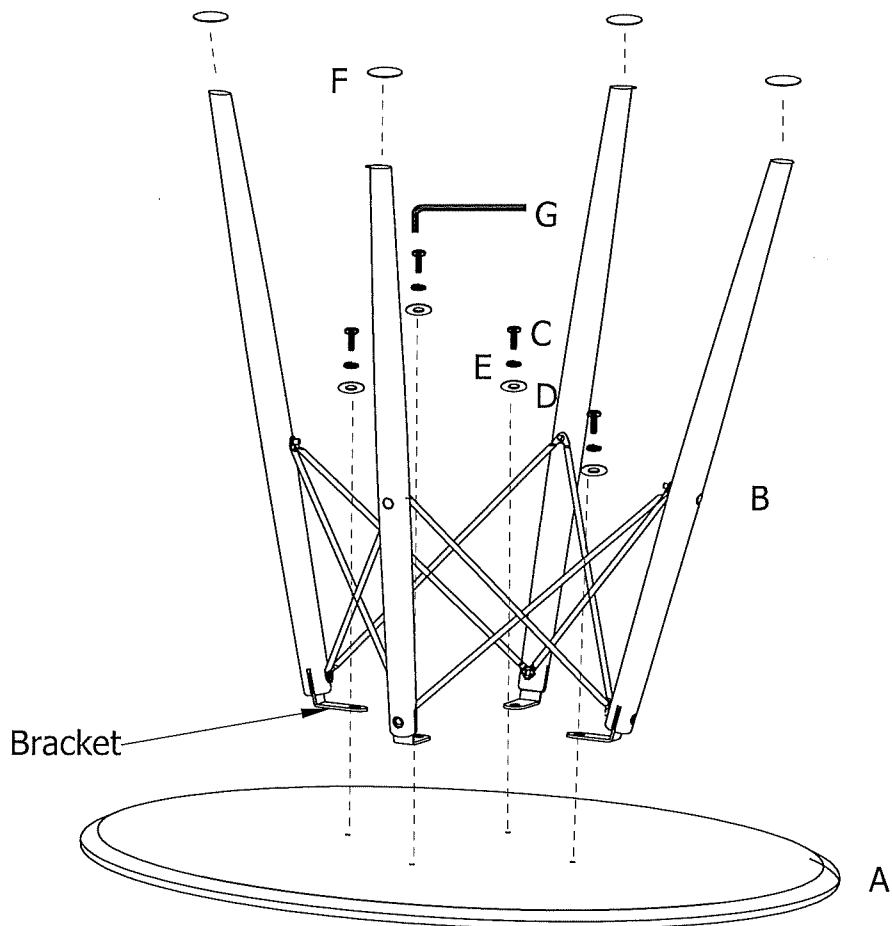

- a) Place Table Top (A) bottom-side faced up on a material that does not scratch or damage its surface.
- b) Position screw holes on leg bracket over pilot holes on (A). Use Screw (C) fitted with Spring Washer (E) and Flat Washer (D) to fasten (A) to Leg (B). Use Allen Key (G) to drive (C). Do not tighten (C) completely until all 4 screws are in place.
- c) Affix Mat (F) to the bottom of each leg. The assembly of the table is complete. Place the table upright.